

Description

The E4P miniature encoder is designed to provide digital quadrature encoder feedback for high volume applications with limited space constraints. The E4P version utilizes an innovative patent pending push-on codewheel which accepts shaft diameters of 1.5mm to .250".

The E4P encoder is the leader for high quantity OEM applications, but the E4 is the ideal choice when a set-screw codewheel encoder is required (see the E4 page).

The E4P miniature encoder base provides mounting holes for two #3-48, length 1/4" or two M2.5x.45mm, length 6mm screws on a .586" bolt circle. When mounting holes are not available, a pre-applied transfer adhesive (with peel-off backing) is available for "stick-on" mounting.

The encoder cover is easily snapped onto the base and is embossed with the connector pin-out.

The E4P series encoder can be connected by using a (high retention 4-conductor snap-in polarized 1.25mm pitch) connector. Mating cables and connectors (see the Cables / Connectors web page) are not included and are available separately.



Features

- ▶ Miniature size
- ▶ Push-on hub - spring loaded collet design
- ▶ Minimum shaft length of .375"
- ▶ Fits shaft diameters of .059" to .250"
- ▶ Accepts +/- .020" Axial shaft play
- ▶ Off-axis mounting tolerance of .010"
- ▶ 100 to 360 cycles per revolution (CPR)
- ▶ 400 to 1440 pulses per revolution (PPR)
- ▶ Single +5V supply

Related Products & Accessories

- ▶ CA-FC5-SH-MIC4 5-Pin Latching / 4-Pin Micro Shielded Cable (Base price \$15.18)
- ▶ CA-MD6-SS-MIC4 6-Pin Modular / 4-Pin Micro Silver Satin Cable (Base price \$11.53)
- ▶ CA-MIC4-SH-NC 4-Pin Micro / Unterminated Shielded Cable (Base price \$7.30)
- ▶ CA-MIC4-W4-NC 4-Pin Micro / Unterminated 4-Wire Discrete Cable (Base price \$6.80)
- ▶ CON-MIC4 4-Pin Micro Connector (Base price \$3.15)
- ▶ MCTOOL Centering Tool for E4, E4P, and E8P (Base price \$5.25)
- ▶ SPACER Spacer Tool (Base price \$0.95)

Mechanical Drawing

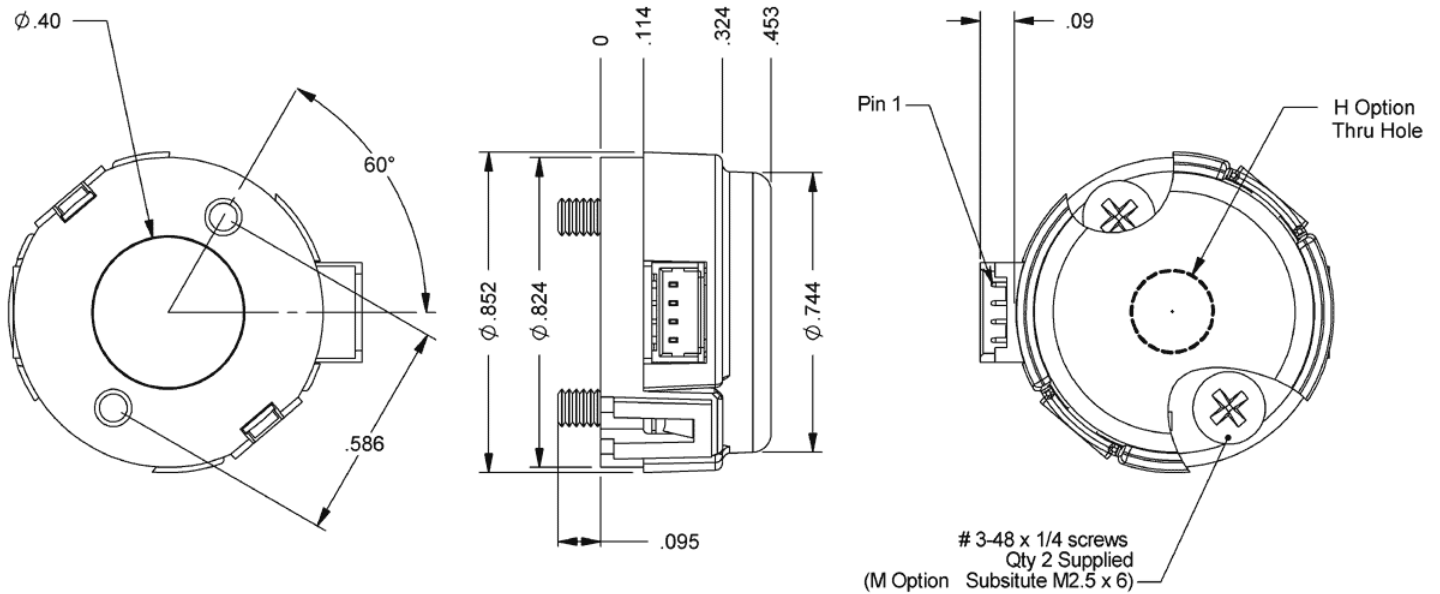

Mechanical

Parameter	Dimension	Units
Moment of Inertia	3.0×10^{-6}	oz-in-s ²
Mounting Screw Size	#3-48 x 1/4"	-
M-option Screw Size	M2.5x.45mm, length 6mm	-
Screw Bolt Circle Diameter	$.586 \pm .002$	in.
Required Shaft Length*	$.375$ to $.395$	in.
Axial Length Codewheel	$.270$	in.

* Includes axial play.

Absolute Maximum Ratings

Parameter	Min.	Max.	Units
Vibration (5 to 2kHz)	-	20	g
Shaft Axial Play	-	$.020$	in.
Off-axis Mounting Tolerance	-	$.010$	in.
Acceleration	-	250,000	rad/sec ²
Maximum RPM e.x. CPR = 360, max. rpm = 10000 e.x. CPR = 100, max. rpm = 36000	-	minimum value of ($3600000/\text{CPR}$) and (60000)	rpm
Relative Humidity	-	90	%
Storage Temperature	-40	100	C

Parameter	Min.	Max.	Units
Operating Temperature	-20	100	C

› Note: 60000 rpm is the maximum rpm due to mechanical considerations. The maximum rpm due to the module's 60kHz maximum count frequency is (3600000/CPR).

Phase Relationship

A leads B for clockwise shaft rotation, B leads A for counter clockwise shaft rotation viewed from the shaft/bushing side of the encoder (see the AEDR page).

Electrical

For complete details see the AEDR page.

Torque

Parameter	Torque
Base to Mounting Surface	2-3 in.-lbs.

Options

H-option (Hole In Cover)

The H-option adds a hole in the cover for the shaft to pass through:

- › For shaft diameters of 1.5mm to 2.5mm, a 0.143" hole is supplied.
- › For shaft diameters of 3mm and 1/8", a 0.170" hole is supplied.
- › For shaft diameters of 5/32" to 5mm, a 0.242" hole is supplied.
- › For shaft diameters of 6mm and 1/4", a 0.295" hole is supplied.

L-option (Low Power Strobe)

To reduce the average power requirements, the L-option version of the E4P power can be strobed on just long enough to sample outputs A and B. This option is the same as our standard E4P, except the internal power bypass capacitor is not installed. The outputs settling time is typically 200 to 400 nano seconds after power up. The minimum sample frequency must be less than the maximum RPM X the CPR / 10.

M-option (Metric Mounting Screws)

Provides alternate metric M2.5x.45mm, length 6mm screws. When M-option is NOT specified the default is #3-48 x 1/4" screws.

T-option (Transfer Adhesive)

When mounting holes are not available, a pre-applied transfer adhesive (with peel-off backing) is available for "stick-on" mounting. Use the centering tool (above) to position the base. T-option specifies transfer adhesive.

Before installation, cleaning the mounting surface with alcohol is recommended to remove dust and oil.

Accessories

Centering Tool

Part #: MCTOOL - (Shaft Diameter*)

Description: This reusable tool provides a simple method for accurately centering the E4P base onto the shaft.

Material: Aluminum.

Please note: A centering tool is highly recommended when using the T-option transfer adhesive.

* See Ordering Information below for available Shaft Diameters.

Spacer Tool



Part #: SPACER-E4P

Description: This reusable tool is used to properly space the codewheel from the encoder base. Provides air gap of 0.07" to 0.03".

Material: Polycarbonate.

Please note: Each order includes at least one spacer tool per 100 encoders.

Pin-out

Pin	Description
1	+5VDC power
2	A channel
3	Ground
4	B channel

Assembly Instructions

View the PDF version of this document.

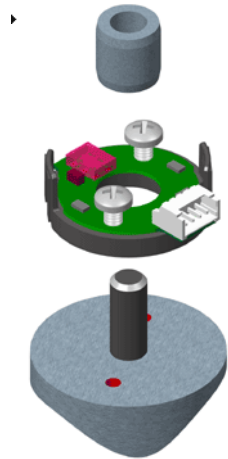

1. Base Mounting

Place base onto shaft. Secure base to mounting surface using two screws.

Transfer Adhesive: Peel off paper backing, place centering tool into center hole of base, slip centering tool onto shaft and slide base and centering tool down onto mounting surface as one piece. Press to form a good bond, then slip centering tool off shaft and continue with standard mounting instructions.

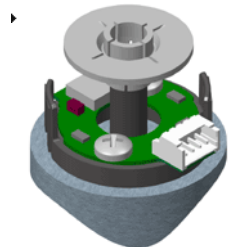

2. Codewheel Placement

Place codewheel onto shaft with pattern-side down towards base.

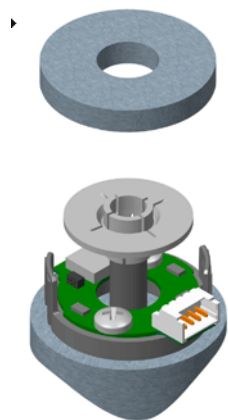

3. Codewheel Installation

Position spacer / installation tool onto codewheel. Spacer / installation tool provides an air gap of $0.07" \pm 0.03"$. Press down firmly until tool bottoms out on base latching ears.

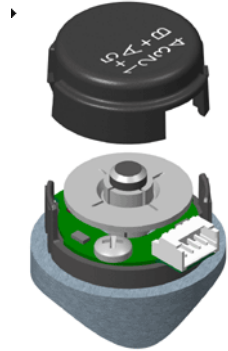

4. Cover Installation

Place housing (cover) on. With thumb and finger, squeeze ears together to insure that cover fully latches.

Ordering Information

E4P	CPR	Bore	Power	Cover	Base	Packaging
- [] - [] - [] - [] - [] - []	100	059 =	D =Default	D =Default	D =Default	B =Encoder components packaged in bulk. One spacer tool per 100 encoders.
	108	1.5mm	L =Low	H =Hole in Cover	M =Alternate metric	1 =Each encoder packaged individually with one spacer tool per 100 encoders.
	120	079 =	Power		M2.5x.45mm, length 6mm screws	2 =Each encoder packaged individually with one spacer tool per encoder.
	125	2mm	Strobe		T =Transfer Adhesive	3 =Each encoder packaged individually with one spacer tool and one centering tool per encoder.
	128	091 =				
	200	2.3mm				
	250	098 =				
	256	2.5mm				
	300	118 =				
	360	3mm				
		125 = 1/8"				
		156 =				
		5/32"				
		157 =				
		4mm				
		188 =				
		3/16"				
		197 =				
		5mm				
		236 =				
		6mm				
		250 = 1/4"				

Notes

- Cables and connectors are not included and must be ordered separately.
- US Digital warrants its products against defects in materials and workmanship for two years. See complete warranty for details.

Base Pricing

Quantity	Price
1	\$25.25
10	\$19.84
50	\$17.26
100	\$15.21

- Add 15% per unit for **Base** of Transfer Adhesive
- Add \$3.00 per unit for **Packaging** of Each encoder packaged individually with one spacer tool per 100 encoders.

- ▶ Add \$4.00 per unit for **Packaging** of Each encoder packaged individually with one spacer tool per encoder.
- ▶ Add \$7.00 per unit for **Packaging** of Each encoder packaged individually with one spacer tool and one centering tool per encoder.