

Model#	DM3012-1063	Controller Type:	Green Drive	Encoder PPR:	0	Amb. Temp. (°C):	22	Date:	08/09/2017
--------	-------------	------------------	-------------	--------------	---	------------------	----	-------	------------

**Speed / Torque Test Data - Control set at 100% duty cycle.**

Rated Speed	Rated Current	Rated Power	Rated Torque	No Load Speed	No Load Current	Peak Torque	Peak Current	Voltage Constant	Torque Constant	L-L Resistance	L-L Inductance	Rotor Inertia	Voltage
RPM	Amp	Watt	Oz.in	RPM	Amp	Oz.in	Amp	V/kRPM	oz.in/Amp	Ohms	mH @ 1KHz	oz.in.sec <sup>2</sup>	Volts
1700	4.00	44.00	20.00	2700.00	0.28	45.00	6.50	3.89	5.26	0.67	0.66	0.0013	12.00

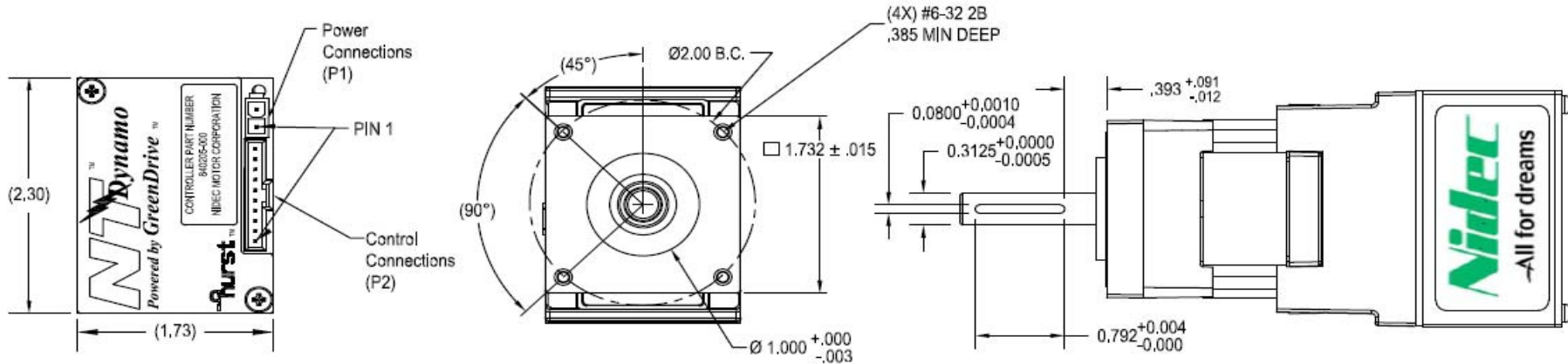

ROL CONNECTIONS			
PIN#	DESCRIPTION	PIN#	DESCRIPTION
1	BLANK	6	BLANK
2	BLANK	7	PWM/DIREC
3	BLANK	8	RUN/STOP
4	BLANK	9	RETURN
5	BLANK	10	+5VDC
POWER CONNECTIONS			
1	+VS	2	RETURN

